

The Questionnaire about Factors Affecting Enactment of Competency-based English Teaching Curriculum: A Developing and Validating Method

Thanh Vinh Chau*

Thao Quoc Tran

Ho Chi Minh City Open University, Vietnam

Received: 1 March 2025 / Received in revised form: June 1 2025 / Accepted: August 6 2025 / Available online: 18 August 2025

Abstract

To capture Vietnamese high school English teachers' driving forces and barriers in enacting the Competency-Based English Teaching Curriculum (CBETC), this study presents the method of designing and developing a questionnaire. It also validates its structure and reliability when used as a survey in the classroom. The relevant theories were analyzed to construct their content and form. Two techniques, Exploratory Factor Analysis (EFA) and Confirmatory Factor Analysis (CFA), were utilized to assess the construct validity and reliability, while internal consistency was evaluated using Cronbach's alpha (α). The results showed that the questionnaire identified dimensions of impetus through three distinct factors: English curriculum-related, teacher-related, and teaching method-related. Similarly, hindrances were measured through three corresponding factors: English curriculum-related, teacher-related, and institution-related aspects. EFA and CFA results confirmed the construct validity of the instrument, with the impetus scale comprising 10 items across three factors (KMO = 0.77; $p=0.000$; Chi-square/df = 2.066, GFI = 0.976, CFI = 0.982, RMSEA = 0.045; PCLOSE = 0.665; $\alpha = 0.79$; and CR=0.825), and the hindrance scale comprising 12 items also grouped into three factors (KMO = 0.84; $p<0.001$; Chi-square/df = 1.912; GFI = 0.969; CFI = 0.982; RMSEA = 0.042; PCLOSE = 0.845; $\alpha = 0.84$; and CR=0.845). These findings indicate that the instrument demonstrates acceptable levels of validity and reliability, supporting its use in future research on teachers' motivational and contextual factors influencing CBETC implementation.

Keywords

CBETC, impetus, hindrances, questionnaire development, curriculum enactment, instrument validation

*Corresponding author. Email: thanhcv.24at@ou.edu.vn

1 Introduction

The global movement towards competency-based education (CBE) has significantly influenced curriculum reform, particularly in preparing learners with transferable skills such as critical thinking, communication, collaboration, and problem-solving (Voogt & Roblin, 2012; Mulder, 2017). In English language teaching (ELT), CBETC has been adopted in many countries to promote learner-centered instruction and performance-based assessment, encouraging students to acquire language knowledge and demonstrate communicative competence in real-world contexts (Richards & Rodgers, 2014). However, it is a fact that the implementation of CBETC at the classroom level is complex and influenced by many contextual, institutional, and teacher-related factors (Fullan, 2007; Orafi & Borg, 2009). In other words, effective curriculum implementation requires a convergence of factors that facilitate the enactment of policy intentions. These factors include teacher motivation, professional training, and overcoming barriers in classroom practice (Borko, 2004; Opfer & Pedder, 2011). In particular, teachers' agency is central in interpreting and translating curriculum innovations into practice. Teachers' enactment of CBETC depends not only on their understanding of competencies but also on pedagogical competence, institutional support, and the degree of congruence between curriculum goals and classroom practice (Borg, 2006; Priestley et al., 2015).

Despite growing scholarly interest in competency-based education, there is a lack of studies about the development of validated instruments or research on the method in designing and validating the research instrument to measure factors influencing teachers' CBETC enactment behavior (Nieveen & Kuiper, 2012). Existing studies rely on computational methods such as interviews and problem-based research (e.g., Priestley et al., 2015), which provide contextual insights but limit more intelligent insights. Therefore, developing and validating a standardized and theoretically grounded questionnaire would allow researchers to assess key influencing factors on a larger scale, compare fidelity across contexts, and provide targeted potential solutions to support teachers in improving their teaching. Therefore, this present study aims to fill the gap by discussing the method of developing and validating a questionnaire to identify and measure factors influencing the implementation of CBETC. Based on the review of relevant literature, the questionnaire was designed to measure indicators of teachers' motivation and the difficulties they encounter. Therefore, the primary method was applying two techniques, exploratory factor analysis (EFA) and confirmatory factor analysis (CFA) calculations. The method of development and validation of the survey followed strict procedures, including item generation, expert assessment of content validity, pilot testing, and validation through EFA and CFA calculations (DeVellis, 2016; Worthington & Whittaker, 2006). Accordingly, the EFA analysis method was used to identify the latent structure of the questionnaire and remove items that were not statistically or theoretically appropriate. Then, confirmatory factor analysis (CFA) was applied to validate the measurement model and test the model's fit with the actual data (Brown, 2015; Hair et al., 2019).

Combining EFA and CFA is a popular and recommended method in measuring educational instruments (DeVellis, 2016). This paper thus contributes to the demonstration and validation of the method to develop and validate an instrument with a solid theoretical and statistical basis, serving research and teaching practice according to the CBETC program in the context of general education in Vietnam.

2 Literature Review

2.1. Enactment of competency-based English teaching curriculum

According to Remillard's (2005) theory and expanded by Priestley, Biesta, and Robinson (2015), the enactment of a curriculum is generally a process of interpreting and using pedagogically relevant teaching practices in the context of appropriate institutional and educational policies by teachers, not

simply the implementation of prescribed materials. In this process, teachers play an active and pivotal role in transforming curriculum content through classroom teaching activities, not passive recipients of curriculum mandates. This perspective highlights curriculum enactment's dynamic and contextually responsive nature, particularly in CBETC, where competencies are often broadly defined and subject to interpretation according to each country's objectives (Leat, Livingston & Priestley, 2013).

CBETC enactment is how teachers interpret and implement curriculum frameworks by implementing teaching activities that build on students' language learning competencies in the classroom (Remillard, 2005). This application of CBETC is not linear, but teachers actively construct teaching plans and make implementation decisions in a situation influenced by teachers' beliefs, experiences, and institutional contexts (Remillard, 2005; Priestley, Biesta & Robinson, 2015). In the context of CBETC, enactment requires teachers to adapt pedagogy to align with and develop learners' real-world competencies, such as communication, critical thinking, and autonomy (Richards & Rogers, 2014; OECD, 2018). In this view, promulgation is not a simple application of teaching materials but a highly specialized process of transforming teaching content and methods.

2.2 Teachers' impetuses for CBETC enactment

The successful implementation of CBETC in high schools depends largely on teachers' impetus, which includes intrinsic, extrinsic, and professional factors that influence their teaching behaviors and decisions. These motivations not only influence their readiness to accept the new curriculum but also determine the quality of the curriculum implementation in classroom practice (Fullan, 2007; Kelchtermans, 2009). First, professional beliefs are an important driving force for teachers to approach CBETC positively. CBETC emphasizes developing communication skills, critical thinking, collaboration, and lifelong learning for students (MOET, 2018). Therefore, when teachers believe in the importance of learner-centered education and want students to develop comprehensively, they will easily approach and implement the program. This intrinsic motivation often stems from personal teaching philosophy and career satisfaction (Vähäsantanen, 2015).

In addition, professional development opportunities play a significant role in promoting teachers' motivation to act. When teachers can participate in substantive training courses, receive professional support, and share experiences with colleagues, they will feel competent to change their teaching methods per CBETC (Guskey, 2002; Hord, 1997). Exposure to more experienced environments from colleagues or instructional materials increases teachers' self-efficacy and initiative (Vescio et al., 2008). In addition, teachers' professional identity and ownership of the curriculum are also key factors in creating motivation. When seen as co-creators of the curriculum with a decisive role in designing and adjusting teaching activities, teachers will feel more recognized and responsible for implementing CBETC (Beijaard et al., 2004; Priestley et al., 2015).

Finally, positive feedback from students, such as improvements in communication skills, self-learning ability, and interest in the subject, is the practical motivation for teachers to maintain and improve the implementation of CBETC. Student learning outcomes are direct evidence of the effectiveness of teaching methods, thereby creating motivation to continue to innovate (Deci & Ryan, 2000).

In summary, teachers' motivation to implement CBETC in general schools results from personal values, policy regulations, professional development opportunities, professional identity, and student feedback. Understanding and enhancing these motivations is the foundation for sustainable and effective program implementation.

2.3 Teachers' hindrances to enact CBETC

Implementing CBETC in secondary schools is a complex process, requiring educational philosophy, teaching methods, and changes in student assessment to match students' abilities. However, many

teachers face significant barriers from traditional teaching to competency-based learning. These barriers can stem from individual, organizational, systemic, and socio-cultural contexts (Fullan, 2007). One of the most prominent barriers is that teachers lack a deep understanding of the nature and principles of CBETC. Although many teachers have attended training courses, most have only had access to theoretical content and have not had the opportunity to practice or transform that knowledge into specific teaching skills. This makes CBETC implementation formalistic, formulaic, or confusing old and new methods (Nguyen et al., 2023). Richardson (1996) argues that pedagogical beliefs are closely linked to teaching experiences and are difficult to change without profound impact from practice or guided reflection.

Second, the limited capacity to design competency-based teaching activities is a significant barrier. CBETC requires teachers to develop integrated, task-oriented, personalized, and case-based teaching activities. However, many teachers report difficulty designing and implementing lessons in this direction due to unfamiliarity with reverse design thinking or lack of proficiency in competency assessment tools (Wiggins & McTighe, 2005). In addition, inadequate teaching practice conditions also hinder the practical application of CBETC. Large class sizes, limited learning time, and lack of equipment and supporting materials are common factors reported by teachers (MOET, 2018). These conditions make it difficult for teachers to organize group activities, personalize instruction, and leave insufficient time to assess individual student progress – key requirements of CBETC (Griffith & Lim, 2014).

Lack of professional support and learning communities is also a psychological and professional barrier for teachers. Many teachers feel isolated when implementing innovation, lacking companions to exchange feedback and learn from each other. Priestley et al. (2015) emphasize that teachers' agency can only be developed sustainably when placed in an environment that supports and encourages professional creativity.

Finally, the inability of the professional identity to adapt to the new roles required by CBETC is also a profound barrier. Teachers must move from being transmitters of knowledge to learning designers, facilitators of competency development, and continuous assessors. This shift requires teachers to re-evaluate their role – a process that is not easy without support from policy and the educational community (Beijaard et al., 2004). In short, barriers to CBETC implementation in secondary schools are systemic and closely linked between individuals, organizations, and policies. Overcoming these barriers requires intensive training programs, a supportive professional environment, and synchronization in testing, assessment, and education management policies.

2.4 Methods in survey development and validation

Developing and validating reliable instruments to measure latent constructs represents a paramount methodological undertaking in educational research. Particularly, this is relevant when examining complex and context-specific phenomena, such as enacting CBETC. Because CBETC implementation involves a complex interplay of multiple interrelated factors—including curriculum understanding, teacher beliefs, instructional design, assessment practices, organizational conditions, and policy mediation, especially motivation and challenges—a well-constructed questionnaire is indispensable to accurately capture these multifaceted dimensions (Richards & Rodgers, 2014; Carlgren, 2020). Therefore, the survey development and validation process must adhere to a systematic and theoretically based framework to ensure reliability and construct validity. Among the widely applied statistical techniques for instrument validation, Exploratory Factor Analysis (EFA) and Confirmatory Factor Analysis (CFA) play a central role, often used in combination to develop and refine the theoretical structure underlying survey items (Worthington & Whittaker, 2006; DeVellis, 2016).

2.4.1 Theoretical foundations of survey development in CBETC context

The development of a survey instrument begins with a precise conceptualization of the constructs intended to be measured, grounded in theoretical frameworks, and a thorough review of the existing literature. Within the scope of the Competency-Based English Teaching Curriculum (CBETC), key constructs often encompass domains such as instructional design, differentiated instruction, the application of diverse teaching strategies, and progression based on learners' mastery levels—core components frequently highlighted in competency-based education models (Spady, 1994; Carlgren, 2020). Following this theoretical grounding, a comprehensive pool of survey items is typically generated, which is then subjected to refinement processes such as expert judgment and cognitive pretesting to ensure content relevance and clarity (Boateng et al., 2018). After establishing the preliminary instrument, empirical validation becomes essential, wherein Exploratory Factor Analysis (EFA) and Confirmatory Factor Analysis (CFA) are employed to investigate the underlying factor structure and assess the psychometric robustness of the scale.

2.4.2 Exploratory factor analysis (EFA): discovering underlying structures

Exploratory factor Analysis (EFA) is a statistical approach designed to reveal the latent structure within a large set of observed variables without imposing any prior assumptions about the underlying model. This technique is especially appropriate during the initial stages of scale construction, where the dimensionality of the construct has yet to be established or empirically validated (Fabrigar & Wegener, 2012). The underlying premise of EFA is that observable items are indicators of fewer unobserved (latent) variables, and by analyzing the intercorrelations among these items, researchers can infer the presence of latent constructs (Hair et al., 2019).

Conducting EFA involves a series of methodological decisions, including the selection of an extraction method—commonly principal axis factoring—the determination of the number of factors to retain based on criteria such as eigenvalues greater than one, scree plot analysis, and the choice of factor rotation technique. Rotation methods can be orthogonal (e.g., Varimax) or oblique (e.g., Promax) to improve interpretability by simplifying factor loadings (Costello & Osborne, 2005). Items are typically retained if they demonstrate factor loadings of 0.40 or higher and do not exhibit substantial cross-loadings, thereby supporting conceptual clarity and factorial validity. When applied in the context of CBETC, EFA serves as a foundational tool to examine whether theoretically posited dimensions are statistically distinct and interpretable in empirical data.

2.4.3 Confirmatory factor analysis (CFA): testing the measurement model

Whereas Exploratory Factor Analysis (EFA) is employed to identify potential underlying structures within a dataset, Confirmatory Factor Analysis (CFA) verifies and validates a hypothesized factor model, theoretically informed or derived from prior exploratory analysis. This method enables the assessment of the extent to which a set of observed variables accurately represents their corresponding latent constructs while also evaluating how well the proposed measurement model fits the empirical data (Brown, 2015). Model fit is typically assessed using several indices, including the Chi-square to degrees of freedom ratio (acceptable if less than 3), Comparative Fit Index ($CFI \geq 0.90$), Tucker-Lewis Index ($TLI \geq 0.90$), Root Mean Square Error of Approximation ($RMSEA \leq 0.08$), and Standardized Root Mean Square Residual ($SRMR \leq 0.08$) (Kline, 2016; Hair et al., 2019). Also, CFA provides a framework for evaluating convergent validity, typically indicated by standardized factor loadings of 0.50 or higher and an Average Variance Extracted (AVE) of at least 0.50. Moreover, the reliability of the constructs is measured through Cronbach's Alpha, with a threshold of 0.70 or higher, complemented by internal consistency indicators such as Cronbach's alpha. Therefore, these validation procedures are very essential to confirm that key

constructs—such as “teachers’ impetus and their hindrances—” are “not only statistically so” but also meaningful for” theoretical advancement and practical application in curriculum reform.

2.4.4 Integrating EFA and CFA: a sequential validation approach

Contemporary methodological guidelines in scale development emphasize the sequential application of Exploratory Factor Analysis (EFA) followed by Confirmatory Factor Analysis (CFA), ideally conducted on separate samples or by utilizing a split-sample strategy. This phased approach is recommended to minimize overfitting and enhance the external validity and generalizability of the measurement model (Worthington & Whittaker, 2006). In this process, EFA serves to uncover data-driven factor structures that are subsequently tested and confirmed using CFA. Through this dual-phase validation, researchers can ensure that the resulting instrument is aligned with theoretical expectations and performs consistently across educational settings.

This sequential approach proves particularly beneficial when developing a questionnaire to assess the factors influencing the enactment of the CBETC in Vietnam. It facilitates the creation of a measurement tool that is context-sensitive while remaining theoretically coherent. Given the multifaceted nature of CBETC implementation—encompassing curriculum-pedagogy alignment, teacher decision-making autonomy, and institutional resource support—a rigorously validated instrument enables a nuanced and comprehensive exploration of these factors across key educational stakeholders.

In conclusion, the integrated use of EFA and CFA is a cornerstone of robust survey design, particularly for studies investigating the implementation of educational innovations such as CBETC. These analytical techniques allow researchers to explore latent variable structures, evaluate construct validity and reliability, and produce psychometrically sound tools grounded in theory and data (DeVellis, 2016; Hair et al., 2019). For research focused on CBETC in Vietnamese secondary education, this methodological rigor provides a solid foundation for generating meaningful insights and informing policy and practice. Ultimately, a validated instrument developed through EFA and CFA offers researchers and practitioners a reliable basis for understanding and enhancing competency-based English instruction in the national education system.

3 Research Methodology

3.1 Research design

The quantitative research design method is used to develop and validate a questionnaire to measure the factors affecting the enactment of CBETC. This validation process follows the instrument development and validation model, including item generation, pilot testing, exploratory factor analysis, and confirmatory factor analysis (Taherdoost, 2016). Factor analysis is a widely used statistical method in developing and validating questionnaires, particularly when examining the underlying structure of latent constructs such as beliefs, attitudes, or practices (Fabrigar et al., 1999). In educational research, including studies on teachers’ enactment of CBETC, factor analysis is essential for establishing the construct validity of a newly developed instrument.

Specifically, the development of questionnaire items examining factors affecting the enactment of the Competency-Based English Teaching Curriculum (CBETC) followed a theory-driven approach. Items were generated based on an extensive review of relevant literature and conceptual frameworks, particularly Activity Theory (Engeström, 2001) and Carlgren’s (2020) framework on curriculum enactment. Key themes such as instructional design, teacher capacity, institutional support, and classroom conditions were identified and translated into measurable indicators. The initial pool of items was reviewed by content experts to ensure relevance and clarity, following best practices in scale development (Artino et al., 2014).

Moreover, exploratory factor analysis (EFA) allows researchers to identify clusters of related items that represent underlying dimensions or factors (Brown, 2015). These factors are not directly observable but are inferred from patterns of correlations among questionnaire items. Through this process, EFA helps ensure that each group of items consistently measures a specific theoretical construct, such as teachers' motivation and challenges. Using factor analysis also enables researchers to refine the questionnaire by removing items that do not load significantly on any factor or exhibit cross-loadings, which would indicate ambiguity in what they measure. This enhances the internal consistency and clarity of the instrument (DeVellis, 2016).

Additionally, factor analysis contributes to data reduction by summarizing many items into a smaller set of interpretable factors. This is beneficial for creating concise and practical instruments for large-scale use (Fabrigar & Wegener, 2012). Moreover, confirmatory factor analysis (CFA) was used to validate the theoretical structure of the questionnaire, which measured teachers' motivations and barriers. CFA allows the test of the level of fit between the hypothesized measurement model and the empirical data, thereby ensuring the construct validity and reliability of the instrument. Using CFA confirms that the theoretical factors have been measured accurately and validly (Brown, 2015).

Briefly, factor analysis, including EFA and CFA, provides empirical and valid evidence about the structure of the questionnaire, making it an important step in validating the questionnaire's reliability as the primary instrument in measuring teachers' impetuses and hindrances in an educational context.

3.2 Participants and sample size

3.2.1 Participants

The participants in this study included Vietnamese high school English teachers who are developing a new form of English teaching. A convenience sampling method for the quantitative data was used to select the participants. Convenience sampling is a non-probability sampling technique in which participants are selected based on their accessibility, availability, and willingness to participate (Etikan, Musa, & Alkassim, 2016). This technique is particularly suitable for this study because the research context took place in many high schools, with limited time and sampling resources. Convenience sampling was chosen for use in this study because it helps to quickly access subjects directly related to implementing CBETC. The sample source was collected through existing relationships, colleagues' referrals, and teachers' professional networks. Although it is a convenient method, it still ensures reasonable sampling criteria by selecting teachers with at least one year of teaching experience according to the new program to ensure suitability with the research objectives (Creswell & Creswell, 2018). The criteria for sampling selection consist of three aspects, as summarized in the following table:

3.2.2 Sample size

This study used the theory of Hair et al. (2019) about the sample size determination to determine the number of participants needed for the survey. Accordingly, to ensure the reliability of the survey results, this principle requires at least 5 participants to answer 1 item. The formula is summarized as follows:

Sample size (n) = Number of items x (Ratio of item:1)

With the initial questionnaire having 24 items, the total number of people needed to be surveyed is at least 120 participants. As the following formula:

Sample size (n) = 24 x (5:1) = 120

According to the results from the formula, this study needs at least 120 participants. However, the feedback results after sending the survey within 05 weeks, 570 teachers participated in answering. However, only 517 responses were statistically significant, and 53 were eliminated due to missing data

and straight-lining violations. This quantity is more than the minimum required to ensure quantitative reliability.

The sample of 517 Vietnamese high school English teachers was divided into two independent subsamples to ensure methodological rigor in scale validation. In the first phase, data from 250 participants were utilized to conduct Exploratory Factor Analysis (EFA) to identify the instrument's underlying factor structure. In the second phase, the remaining 267 responses were used to perform Confirmatory Factor Analysis (CFA) to validate the factor structure derived from EFA. This two-step approach aligns with established recommendations for scale development and construct validation in educational research (Worthington & Whittaker, 2006; Hair et al., 2019).

Table 1

Sampling Criteria of this Study

Sampling criteria	Explanation
1. Teachers' accessibility, availability, and willingness to participate (Etikan, Musa, & Alkassim, 2016)	- Currently or previously teaching under the competency-based curriculum (CBETC). - Have participated in training or refresher courses on the CBETC program or the new competency-based curriculum.
2. Teaching experience (Creswell & Creswell, 2018)	- They are high school teachers with at least one year of experience implementing innovative teaching programs, especially the 2018 Vietnam General Education Program.
3. Volunteer and Responsiveness for answering the questions (Etikan, Musa, & Alkassim, 2016)	- Teachers agree to participate voluntarily in the study and provide informed consent, ensuring ethical research conduct. - They can answer the questionnaire in a detailed, transparent, and reflective manner that reflects the actual teaching of CBETC in the classroom.

3.3 Instrument development

This paper uses a questionnaire as a primary instrument to measure the variables about teachers' incentives and hindrances. Initially, the questionnaire consisted of 24 items. It was divided into two main parts: Part C1- Teachers' impetuses for CBETC enactment with 12 question items, and Part C2- Teachers' hindrances to enact CBETC with 12 items. Each factor is designed with at least four items to ensure stability and a clear interpretation of the factors (Costello & Osborne, 2005). The content of the question items was developed from an extensive review of the literature on Activity theory (Engeström, 2001) and Carlgren's (2020) curriculum model about teachers' opportunities and challenges. A 5-point Likert scale ranging from 1 (Strongly disagree), 2 (Disagree), 3 (Neutral), 4 (Agree) to 5 (Strongly agree) is used. To ensure content validity, the initial version of the questionnaire was reviewed by two experts in language education and curriculum research and five Vietnamese high school English teachers. Revisions have been made based on their feedback to improve clarity, relevance, and appropriateness.

Engeström's (2001) Activity Theory (AT) is an effective theoretical tool to explore teachers' motivation (impetus) in implementing CBETC in high schools. According to AT, teachers' actions are not the sole result of individuals but the product of an activity system consisting of many closely linked elements: objects, tools, community, rules, and division of labor. Accordingly, teachers' motivation is formed and maintained when there is consistency between professional goals (objectives) and supporting factors such as documents, training programs (tools), support from schools and colleagues (community), as well as incentive policies (rules). For example, when teachers perceive that implementing CBETC

helps them improve their professional competence and receive appropriate support from their work environment, they are more proactive and positive in implementing the program. Thus, AT allows interpreting teacher motivation as a phenomenon shaped by social interaction and specific educational contexts (Engeström, 2001; Barab et al., 2002).

Moreover, Carlgren's (2020) curriculum model emphasizes that curriculum implementation is not only an act of imparting knowledge but also a process of pedagogical practice that is shaped in a specific social, cultural, and institutional context. In this study, the theoretical framework is beneficial in explaining the barriers that teachers encounter. Carlgren distinguishes three aspects of educational practice: purpose, content, and conditions. Barriers often arise when there is a conflict between the goals of the curriculum (e.g., developing comprehensive competencies) and the practical conditions at school, such as large class sizes, lack of resources, exam pressure, or pedagogical capacity unsuitable for new methods. In addition, the lack of institutional support or specific guidance also makes it difficult for teachers to adjust their practices. Carlgren's theoretical framework thus provides an insightful lens for analyzing the structural and practical constraints in CBETC implementation.

First, based on these two theoretical frameworks, three primary sources of motivation, including teacher-related factors, English curriculum-related factors, and teaching method-related factors, are suggested. The first impetus is the factors related to the English curriculum, which refer to the characteristics of the official curriculum. Carlgren (2020) supported that the elements contained in the promulgated curriculum strongly promote teacher implementation, including clear program goals, developing student progress, and ensuring learning outcomes. Therefore, these factors affect how teachers design and enact teaching and assessment activities.

Second, according to the framework of Activity Theory (Engeström, 2001), teaching is a series of culturally and historically contextualized activities in the classroom. In this context, teacher-related factors are the motivations within teachers themselves that motivate teachers to engage in CBETC practice. In addition, teachers' knowledge and expertise are integral to the curriculum and shape how they interpret and apply the established curriculum (Carlgren, 2020).

Third, factors related to teaching methods are significant motivations, referring to their availability and appropriateness in the CBETC framework. These include student-centered approaches and teachers' skills in integrating different teaching strategies to develop student competencies in authentic contexts. Activity theory (Engeström, 2001) emphasizes the role of tools and artifacts; in this context, teaching methods act as such tools. Briefly, the dynamics of CBETC implementation are shaped by the interaction between teacher dispositions, curriculum design, and teaching methods. Through AT and Carlgren's framework, these factors shed light on the potential influences on curriculum implementation in Vietnamese high schools.

Regarding the difficulties in implementing CBETC in Vietnamese public schools, the questionnaire was built based on Engeström's (2001) Activity Theory and Carlgren's (2020) curriculum model with three factors: English curriculum-related, teacher-related, and educational institution-related. These difficulties represent the internal contradictions in the educational activity system when transforming to competency-based teaching methods.

First, English curriculum-related factors include inconsistencies between program content and objectives with instructional materials, teaching methods, assessments, and the lack of instructional materials. According to Engeström's (2001) Activity Theory, this is a type of object contradiction when the program's objectives of competence development are incompatible with the supporting tools.

Second, teacher-related factors refer to the lack of specialized training in competency-based teaching, confusion in changing the role from transmitting knowledge to supporting competency development, and a lack of practical knowledge and experience. In CBETC practice, subject didactic knowledge, that is, teachers' professional understanding of content, methods, and approaches, will govern how they

implement it, so when teachers are not fully equipped with this type of knowledge, they will find it difficult and lack confidence in implementing it (Carlgren, 2020).

Third, institution-related factors include a lack of support from school administrators and classroom conditions such as student size, classroom environment, and teaching hours that do not meet the requirements for implementing skills integration. These conditions give rise to “community contradictions” and conflicts between teachers’ role expectations and the organizational context (Engeström, 2001). In short, these challenges are important barriers to educational innovation because they are common in practice and reflect systemic incompatibility between elements of educational practice (Engeström, 2001; Carlgren, 2020).

3.4 Data collection procedures

The Google Form collects data and sends it to participants via social networks. Participants were given about 05 weeks to complete this online survey. Participants were informed about the research objectives, and they agreed to participate in completing the questionnaire voluntarily. When the survey was conducted, anonymity and confidentiality were ensured according to research ethics protocols.

Google Forms has emerged as a widely adopted tool for data collection in social science and education research due to its user-friendly interface, cost-effectiveness, and broad accessibility. A significant advantage lies in its ease of dissemination, allowing researchers to distribute surveys via social media to a large and geographically diverse population without incurring additional financial burden (Evan & Mathur, 2018). This feature is particularly useful in studies involving participants such as teachers from multiple schools. Additionally, Google Forms facilitates real-time compilation of responses into linked Google Sheets, streamlining data tracking and allowing easy export to statistical software for further analysis. Overall, Google Forms provides a practical, accessible, and cost-effective solution for conducting large-scale questionnaire-based research on a limited budget.

3.5 Data analysis

This study aimed to develop a new measurement instrument and evaluate its reliability in assessing teachers’ motivation and difficulties in implementing CBETC. Exploratory Factor Analysis (EFA) was used as the primary analysis method, and SPSS version 27.0 was used to validate the internal structure of the questionnaire. EFA helps to explore the latent dimensions underlying the items in the questionnaire and consolidate them into coherent structures. Before conducting EFA, the adequacy of the sample and the adequacy of the data were verified using the Kaiser-Meyer-Olkin (KMO) statistic and Bartlett’s test of sphericity.

Principal Axis Factor Analysis (PAF) combined with Promax rotation was chosen, assuming the possibility of intercorrelated factors, which aligns with the literature’s recommendations (Costello & Osborne, 2005). Items with factor loadings below 0.40 or that exhibited significant cross-loadings were excluded from the analysis to ensure clarity and construct validity (Hair et al., 2019). Reliability estimates for each factor were calculated using Cronbach’s alpha coefficient, with values of 0.70 or higher considered acceptable for internal consistency (Nunnally & Bernstein, 1994).

Based on the EFA results, the questionnaire was refined, resulting in a shorter, more theoretically grounded instrument that captured key aspects of teachers’ motivation and difficulties in implementing CBETC. To further confirm the instrument’s structural integrity, a Confirmatory Factor Analysis (CFA) was conducted through the software AMOS version 24.0. CFA allows testing of the hypothesized factor structure against empirical data using a range of model fit indices (Brown, 2015; Hair et al., 2019). Commonly accepted cutoff values include a Chi-square/df ratio ranging from 1 to 3 for a good model fit

(Kline, 2016), Comparative Fit Index (CFI), and Tucker-Lewis Index (TLI) values of 0.90 for acceptable fit (≥ 0.95 for excellent fit); Root Mean Square Error of Approximation (RMSEA) less than 0.08 for acceptable fit (less than 0.05 for close fit); and PCLOSE is greater than 0.05, indicating that RMSEA is not significantly different from 0, supporting the good fit of the model (Byrne, 2016). By using CFA, this study ensured that the observed indicators fit well with their respective latent constructs, thus strengthening both the construct validity and reliability of the questionnaire.

In this research, two techniques of analyzing the data, including Exploratory Factor Analysis (EFA) and Confirmatory Factor Analysis (CFA), were used to address common latent factor structures in the development and validation of a questionnaire on teachers' beliefs and barriers to implementing CBETC in secondary schools. Combining these two techniques demonstrates a connection with contemporary measurement theory, in which EFA explores latent factor structures based on empirical data. At the same time, CFA is implemented to test the suitability of the hypothesized factor model to the data, thereby ensuring the construct validity of the measurement instrument.

4 Results

4.1 Missing data

A frequency analysis was conducted in SPSS to identify and manage missing data. This procedure allowed the researcher to detect valid and missing cases across all key variables. As a result of Table 2, 53 cases were identified as containing incomplete responses and subsequently excluded from further analysis. The final dataset comprised 517 valid cases, which met the criteria for statistical processing. Frequency analysis is commonly employed in the data cleaning phase to ensure the quality and reliability of subsequent analyses, as it helps identify each variable's distribution and integrity (Field, 2018; Pallant, 2020).

4.2 Characteristics of the sample

A total of 570 teachers were initially recruited for participation in this study. However, only the responses of 517 participants were retained for subsequent analysis due to data quality considerations. Specifically, 53 cases were excluded as a result of incomplete responses (i.e., missing data) and response bias issues such as straight-lining—where participants select the same answer option across multiple items - both of which can threaten the validity of statistical analyses (Meade & Craig, 2012; Hair et al., 2019).

The final sample comprised 517 English teachers, including 282 males and 235 females, indicating a relatively balanced gender representation within the dataset. Regarding age distribution, 16 participants were 23, 177 were between 24 and 28 years old, 162 fell within the 29–33 age group, and 116 were above 33. This age variability reflects generational diversity among the teachers involved in implementing the Competency-Based English Teaching Curriculum (CBETC), providing a valuable basis for analyzing age-related patterns in curriculum enactment (Priestley et al., 2015).

Concerning teaching experience, 72 respondents reported having less than one year of teaching experience, 195 had between one and five years, 154 had taught for six to ten years, and 96 had over ten years of experience. Notably, most participants had between one and ten years of experience, suggesting that early- to mid-career teachers constitute the core workforce contributing to curriculum innovation and reform (OECD, 2018). Furthermore, all respondents indicated prior participation in training or professional development programs related to CBETC. This shared training background is essential for examining variations in teacher awareness, pedagogical competence, and curriculum implementation practices.

Table 2
Results of Frequency of the Questionnaire in this Study

		Missing data		Valid Percent	Cumulative Percent
		Frequency	Percent		
Valid	2.29	1	0.2	0.2	0.2
	2.33	1	0.2	0.2	0.4
	2.38	1	0.2	0.2	0.6
	2.42	2	0.4	0.4	1.0
	2.46	9	1.6	1.7	2.7
	2.50	1	0.2	0.2	2.9
	2.54	7	1.2	1.4	4.3
	2.58	8	1.4	1.5	5.8
	2.63	5	0.9	1.0	6.8
	2.67	5	0.9	1.0	7.7
	2.71	12	2.1	2.3	10.1
	2.75	10	1.8	1.9	12.0
	2.79	9	1.6	1.7	13.7
	2.83	13	2.3	2.5	16.2
	2.88	15	2.6	2.9	19.1
	2.92	13	2.3	2.5	21.7
	2.96	18	3.2	3.5	25.1
	3.00	13	2.3	2.5	27.7
	3.04	27	4.7	5.2	32.9
	3.08	14	2.5	2.7	35.6
	3.13	13	2.3	2.5	38.1
	3.17	15	2.6	2.9	41.0
	3.21	17	3.0	3.3	44.3
	3.25	16	2.8	3.1	47.4
	3.29	13	2.3	2.5	49.9
	3.33	20	3.5	3.9	53.8
	3.38	18	3.2	3.5	57.3
	3.42	11	1.9	2.1	59.4
	3.46	21	3.7	4.1	63.4
	3.50	17	3.0	3.3	66.7
	3.54	8	1.4	1.5	68.3
	3.58	8	1.4	1.5	69.8
	3.63	11	1.9	2.1	72.0
	3.67	19	3.3	3.7	75.6
	3.71	15	2.6	2.9	78.5
	3.75	9	1.6	1.7	80.3
	3.79	16	2.8	3.1	83.4
	3.83	13	2.3	2.5	85.9
	3.88	15	2.6	2.9	88.8
	3.92	6	1.1	1.2	89.9
	3.96	6	1.1	1.2	91.1
	4.00	2	0.4	0.4	91.5
	4.04	6	1.1	1.2	92.6
	4.08	7	1.2	1.4	94.0
	4.13	8	1.4	1.5	95.6
	4.17	6	1.1	1.2	96.7
	4.21	2	0.4	0.4	97.1
	4.25	3	0.5	0.6	97.7
	4.29	2	0.4	0.4	98.1
	4.33	3	0.5	0.6	98.6
	4.38	1	0.2	0.2	98.8
	4.42	3	0.5	0.6	99.4
	4.46	1	0.2	0.2	99.6
	4.50	2	0.4	0.4	100.0
	Total	517	90.7	100.0	
Missing	System	53	9.3		
Total		570	100.0		

4.3 Results of the impetus for teachers' CBETC enactment

As previously outlined, the exploratory factor analysis (EFA) revealed a well-defined and interpretable factor structure. The procedure for identifying and refining the factor model followed a systematic process as recommended by Hair et al. (2019), which included (1) assessing the appropriateness of the dataset for factor analysis through the Kaiser-Meyer-Olkin (KMO) measure, (2) eliminating items with factor loadings below the acceptable threshold of 0.40; (3) assigning items to respective latent factors based on their loading patterns; and (4) evaluating the internal consistency of each factor using reliability estimates.

With the sampling of 250 participants, the results in Table 3 from the initial EFA run showed a KMO value of 0.74, indicating moderate sampling adequacy for conducting factor analysis (Hair et al., 2019). In addition, Bartlett's Test of Sphericity yielded a statistically significant result, $p = 0.000$ ($p < 0.001$), confirming that the correlation matrix was not an identity matrix. This suggests that the observed variables demonstrated sufficient intercorrelation to justify factor extraction.

Table 3

EFA for Measurement of Variables Relating to the Impetus for Teachers' CBETC Enactment in the First Run

English curriculum-related factors	Factor 1	Factor 2	Factor 3
C1.1.1.	0.73	-	-
C1.1.2.	0.74	-	-
C1.1.3.	0.70	-	-
C1.1.4.	0.87	-	-
Teacher-related factors			
C1.2.5.	-	0.97	-
C1.2.6.	-	0.77	-
C1.2.7.	-	0.73	-
C1.2.8.	0.50	0.59	-
Teaching method-related factors			
C1.3.9.	-	-	0.72
C1.3.10.	-	-	0.77
C1.3.11.	-	-	0.81
C1.3.12.	-	-	0.49
Number of items	4	4	4
Kaiser Meyer-Olkin Index	0.74		
Bartlett's test	0.00		

According to the first EFA run results, the loading index in the Communalities table shows that item A1.3.12 has a loading index of 0.27, which is smaller than the standard of 0.40, so it must be eliminated. The remaining items all ensure that the loading factor is higher than 0.40.

As shown in Table 3, item C1.2.8 exhibited significant cross-loadings on multiple factors, indicating ambiguity in its factor alignment. Such cross-loadings reduce the constructs' distinctiveness and discriminant validity, thereby interpreting the factors less precisely and reducing theoretical consistency (Hair et al., 2019). In addition, the cross-loadings on two factors of item C1.2.8 upset the order of the factors. To preserve the quality of the scale and maintain the clarity of each construct, item C1.2.8 had to be removed from the instrument. Removing items with significant cross-loadings is a recognized strategy to enhance construct validity, as it ensures that each item uniquely represents a single latent factor according to theoretical expectations (Tabachnick & Fidell, 2013).

Table 4

EFA for Measurement of Variables Relating to the Impetus for Teachers' CBETC Enactment in the Second Run

English curriculum-related factors	Factor 1	Factor 2	Factor 3
C1.1.1.	0.76	-	-
C1.1.2.	0.75	-	-
C1.1.3.	0.71	-	-
C1.1.4.	0.78	-	-
Teacher-related factors			
C1.2.5.	-	0.95	-
C1.2.6.	-	0.77	-
C1.2.7.	-	0.74	-
Teaching method-related factors			
C1.3.9.	-	-	0.69
C1.3.10.	-	-	0.79
C1.3.11.	-	-	0.84
Number of items	4	3	3
Kaiser Meyer-Olkin Index		0.77	
Bartlett's test		0.00	

Figure 1

CFA Results Plot of Variables Relating to Teachers' Impetus for Enacting CBETC

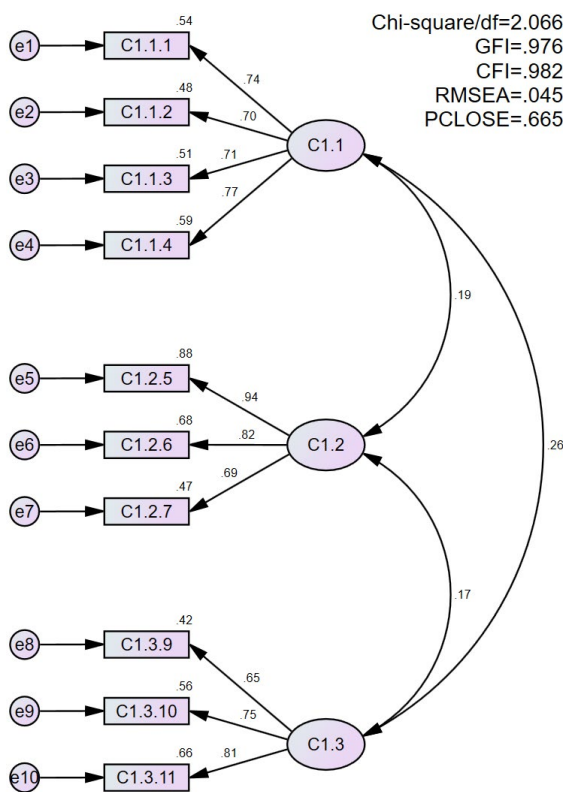

After EFA analysis, data from 267 participants were used for CFA analysis. The results of CFA in Figure 1, Table 4, and 5 showed that the scale in this study has a precise, reliable, and valid measurement structure. In EFA, the selection criteria include factor loading coefficients of observed variables reaching 0.40 or

higher, and each factor must include at least three observed variables, following the recommendations of Hair et al. (2019). At the same time, the KMO index = 0.77, along with the Bartlett test, is statistically significant ($p = 0.000$), showing that the data meet the requirements for factor analysis (Tabachnick & Fidell, 2013). For CFA, the model is considered suitable when the indexes reach the standard level: Chi-square/df = 2.066, GFI = 0.976, CFI = 0.982, RMSEA = 0.045, and PCLOSE = 0.665 (Byrne, 2016; Kline, 2016). The model fit and validity indexes also show that the measurement parameters meet the requirements according to the standards proposed by Hu and Bentler (1999). Therefore, the satisfactory results of both EFA and CFA affirm the construct validity of the survey instrument about teachers' impetus for enacting CBETC.

Table 5

CFA Results of the Model Fit Measures and Model Validity Measures Relating to Teachers' Impetus for Enacting CBETC

Model fit measures							
Measure	Estimate	Threshold	Interpretation				
CMIN	66.105	--	--				
DF	32.000	--	--				
CMIN/DF	2.066	Between 1 and 3	Excellent				
CFI	0.982	>0.95	Excellent				
SRMR	0.045	<0.08	Excellent				
RMSEA	0.045	<0.06	Excellent				
PClose	0.665	>0.05	Excellent				
Model Validity Measures							
	CR	AVE	MSV	MaxR(H)	C1.1	C1.2	C1.3
C1.1	0.820	0.532	0.069	0.822	0.729		
C1.2	0.861	0.678	0.036	0.912	0.189***	0.823	
C1.3	0.782	0.547	0.069	0.797	0.263***	0.173**	0.739

Table 6

The Results of Skewness and Kurtosis of Teachers' Impetus for Enacting CBETC

Statistics											
		C1.1.1	C1.1.2	C1.1.3	C1.1.4	C1.2.5	C1.2.6	C1.2.7	C1.3.9	C1.3.10	C1.3.11
N	Valid	517	517	517	517	517	517	517	517	517	517
	Missing	0	0	0	0	0	0	0	0	0	0
Skewness		0.25	0.24	0.27	0.26	-0.12	-0.28	-0.01	0.03	0.18	0.13
Std. Error of Skewness		0.11	0.11	0.11	0.11	0.11	0.11	0.11	0.11	0.11	0.11
Kurtosis		-0.75	-0.65	-0.62	-0.67	-0.58	-0.58	-0.84	-0.57	-0.77	-0.55
Std. Error of Kurtosis		0.21	0.21	0.21	0.21	0.21	0.21	0.21	0.21	0.21	0.21

The results from Table 6 show that Skewness ranges from -0.28 to 0.27 and Kurtosis from -0.84 to -0.55. All variables are within the allowable threshold, so the data is considered standard, with no serious violations of the univariate normal distribution (Byrne, 2010; Kline, 2016; Alamer, 2025). In addition, the Maximum Likelihood (ML) estimation method in the confirmatory factor analysis (CFA) technique is used to check the standardization of the data. The results from Table 4 and Figure 1 show that the Chi-square/df, GFI, CFI, RMSEA, and PCLOSE indices are all excellent, indicating that the CFA model estimated by ML is suitable for practical use.

Table 7

The Result of Cronbach's Alpha of Variables of Teachers' Impetus for Enacting CBETC

Cronbach's Alpha	N of Items
0.79	10

The results presented in Table 7 indicate that the scale demonstrates an acceptable level of internal consistency, with a Cronbach's alpha coefficient of 0.79. This value exceeds the commonly accepted threshold of 0.70, which is considered adequate for preliminary or exploratory research contexts (George & Mallery, 2003). This suggests that the items within the same construct reliably measure a coherent concept. Drawing on both the outcomes of the exploratory factor analysis and the reliability analysis, it can be inferred that the ten items collectively capture teachers' impetus for enacting CBETC, as detailed in the preceding tables.

Table 8

The Result of Composite Reliability of Variables of Teachers' Impetus for Enacting CBETC

Factor	Items	Standardized Loadings (λ)	Summary
C1.1	C1.1.1	0.729	0.834
	C1.1.2	0.861	
	C1.1.3	0.782	
C1.2	C1.2.5	0.823	0.838
	C1.2.6	0.823	
	C1.2.7	0.739	
C1.3	C1.3.9	0.797	0.802
	C1.3.10	0.739	
	C1.3.11	0.739	

After the teachers' impetus variables were tested for alpha reliability, they were further tested using the Composite Reliability method to establish the composite reliability. Table 8 shows that the results from all items are 0.70, reaching the acceptable threshold (Alamer, 2025). Then, the formula for calculating CR was applied as follows:

$$CR = \frac{(\sum \lambda)^2}{(\sum \lambda)^2 + \sum (1 - \lambda^2)}$$

The results of calculating the composite reliability (CR) for the three latent constructs showed that the values all exceeded the acceptable threshold of 0.70 (Hair et al., 2019), specifically: CR of C1.1 was 0.834, C1.2 was 0.838, and C1.3 was 0.802. CR was 0.825. This shows that the component scales have a high level of internal consistency, reflecting the corresponding latent concepts in the measurement model well.

4.2. Results of teachers' hindrances regarding CBETC enactment

As shown in Table 9 below, the exploratory factor analysis (EFA) of teachers' hindrance variables yielded a Kaiser-Meyer-Olkin (KMO) measure of 0.85, indicating an acceptable level of sampling adequacy for conducting factor analysis (Hair et al., 2019). Bartlett's Test of Sphericity also produced a statistically significant result ($p < 0.001$), confirming that the correlation matrix is sufficiently robust and

the observed variables exhibit adequate intercorrelations for factor extraction. After extraction, the results of commonalities also showed that all 12 items had a loading index higher than 0.40.

Table 9

EFA for Measurement of Variables Relating to Teachers' Hindrances to Enact CBETC

English curriculum-related factors	Factor 1	Factor 2	Factor 3
C2.1.1.	0.73	-	-
C2.1.2.	0.78	-	-
C2.1.3.	0.88	-	-
C2.1.4.	0.86	-	-
Teacher-related factors			
C2.2.5.	-	0.84	-
C2.2.6.	-	0.76	-
C2.2.7.	-	0.76	-
C2.2.8.	-	0.80	-
Institution-related factors			
C2.3.9.	-	-	0.77
C2.3.10.	-	-	0.74
C2.3.11.	-	-	0.75
C2.3.12.	-	-	0.79
Number of items	4	4	4
Kaiser Meyer-Olkin Index	0.85		
Bartlett's test	<0.001		

Figure 2

CFA Results Plot of Variables Relating to Teachers' Hindrances to Enact CBETC

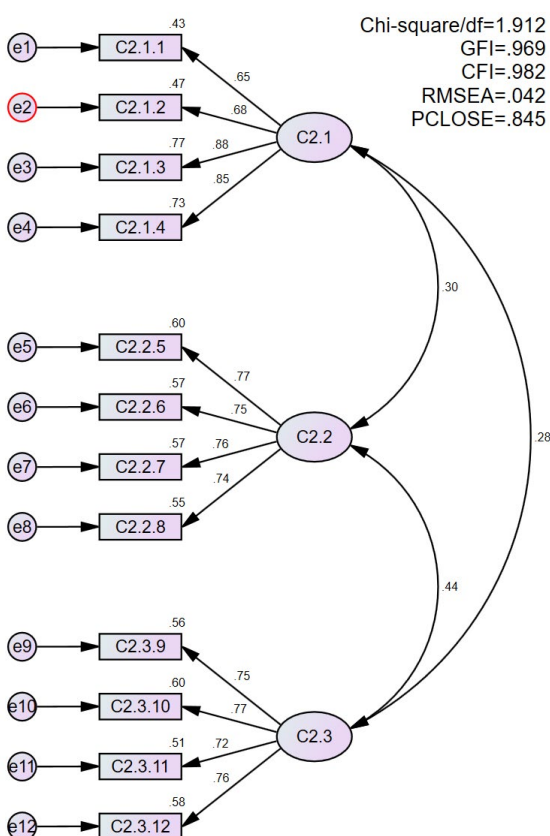

Table 10

CFA Results of the Model Fit Measures and Model Validity Measures Relating to Teachers' Impetus for Enacting CBET

Model fit measures						
Measure	Estimate	Threshold	Interpretation			
CMIN	97.505	--	--			
DF	51.000	--	--			
CMIN/DF	1.912	Between 1 and 3	Excellent			
CFI	0.982	>0.95	Excellent			
SRMR	0.036	<0.08	Excellent			
RMSEA	0.042	<0.06	Excellent			
PClose	0.845	>0.05	Excellent			
Model Validity Measures						
	CR	AVE	MSV	MaxR(H)	C2.1	C2.2
C2.1	0.855	0.600	0.090	0.886	0.774	
C2.2	0.842	0.571	0.192	0.842	0.300***	0.755
C2.3	0.837	0.563	0.192	0.838	0.277***	0.438***

The confirmatory factor analysis (CFA) findings, as presented in Figure 2 and Table 10, indicate that the measurement scale employed in this study possesses a robust, valid, and reliable factorial structure. The model fit indices demonstrated acceptable levels: Chi-square/df = 1.912, GFI = 0.969, CFI = 0.982, RMSEA = 0.042, and PCLOSE = 0.845. These values indicate a good model fit, as supported by the criteria outlined by Byrne (2016), Kline (2016), and Hu and Bentler (1999). The consistency between the EFA and CFA outcomes provides strong evidence for the construct validity of the instrument designed to measure teachers' impetus in implementing the CBETC.

Table 11

The Results of Skewness and Kurtosis of Teachers' Hindrances for Enacting CBETC

		Statistics											
		C2.1.1	C2.1.2	C2.1.3	C2.1.4	C2.2.5	C2.2.6	C2.2.7	C2.2.8	C2.3.9	C2.3.10	C2.3.11	C2.3.12
N	Valid	517	517	517	517	517	517	517	517	517	517	517	517
	Missing	0	0	0	0	0	0	0	0	0	0	0	0
	Skewness	-0.01	-0.31	-0.10	-0.01	0.23	0.14	0.22	0.28	0.01	-0.09	0.00	0.00
	Std. Error of Skewness	0.11	0.11	0.11	0.11	0.11	0.11	0.11	0.11	0.11	0.11	0.11	0.11
	Kurtosis	-0.68	-0.75	-0.73	-0.78	-0.63	-0.69	-0.68	-0.62	-0.88	-0.76	-0.90	-0.77
	Std. Error of Kurtosis	0.21	0.21	0.21	0.21	0.21	0.21	0.21	0.21	0.21	0.21	0.21	0.21

Table 11 shows that the Skewness ranges from -0.31 to 0.28 and the Kurtosis ranges from -0.90 to -0.62. All variables are approximately normally distributed, sufficient for using the Maximum Likelihood (ML) estimation method in AMOS, with no serious violations of the univariate normal distribution (Byrne,

2010; Kline, 2016; Alamer, 2025). The results from Table 10 and Figure 2 show that the Chi-square/df, GFI, CFI, RMSEA, and PCLOSE indices are all excellent, indicating that the CFA model estimated by ML is suitable for practical use.

As shown in Table 12, the scale yields a Cronbach's alpha value of 0.84, indicating satisfactory internal consistency. This coefficient surpasses the benchmark of 0.70, which is generally acceptable for initial or exploratory studies (George & Mallery, 2003). The result implies that the items within the construct exhibit coherent inter-item correlations and measure the same underlying concept reliably. Based on the combined evidence from exploratory factor analysis and internal consistency testing, the twelve items effectively represent the construct of teachers' impetus for implementing CBETC, as reflected in the analyses below.

Table 12

The Result of Cronbach's Alpha of Variables of Teachers' Hindrances to Enact CBETC

Cronbach's Alpha	N of Items
0.84	12

Table 13

The Result of Composite Reliability of Variables of Teachers' Hindrances for Enacting CBETC

Factor	Items	Standardized Loadings (λ)	Summary
C1.1	C2.1.1	0.654	0.855
	C2.1.2	0.685	
	C2.1.3	0.880	
	C2.1.4	0.853	
C1.2	C2.2.5	0.772	0.842
	C2.2.6	0.753	
	C2.2.7	0.756	
	C2.2.8	0.740	
C1.3	C2.3.9	0.750	0.837
	C2.3.10	0.773	
	C2.3.11	0.717	
	C2.3.12	0.760	

Like Impetus, the variables in Hindrances were also tested for overall reliability between items using the CR method. The results from all items in Table 13 were equal to or greater than 0.70, reaching the acceptable threshold. The results of calculating the composite reliability (CR) for the three latent constructs showed that the values all exceeded the above acceptable threshold (Hair et al., 2019; Alamer, 2025), specifically: CR of C2.1 was 0.855, C2.2 was 0.842, C2.3 was 0.837, and CR was 0.845. This shows that the component scales have a high level of internal consistency, reflecting well the corresponding latent concepts in the measurement model of hindrances in CBETC implementation.

5 Discussion

Implementing CBETC requires profound changes in teachers' roles, methods, and beliefs in the context of current general education reform in Vietnam. Teachers gradually shift from the role of simply transmitting knowledge to the role of helping and supporting the development of students'

language competence. One of the important factors affecting the success of implementing CBETC is the motivation (impetus) and the barriers (hindrances) that teachers encounter in the teaching process. To understand and measure these two factors, the construction, development, and validation of a questionnaire on teachers' impetus and hindrances reliably and validly is a necessary step. In this study, the methods of exploratory factor analysis (EFA) and confirmatory factor analysis (CFA) were applied to verify and validate the measurement structure of the questionnaire on teachers' motivation and barriers when implementing CBETC.

The prerequisites for conducting EFA include the Kaiser-Meyer-Olkin (KMO) index reaching the standard level, indicating the suitability of the data for factor analysis (Kaiser, 1974), along with the statistically significant results of Bartlett's Test of Sphericity, confirming that the correlation matrix is eligible for factor extraction. Based on criteria such as factor loading at an acceptable level, eigenvalue exceeding the threshold, and each factor having at least three observed variables to ensure the stability and explanatory ability of the model (Worthington & Whittaker, 2006), the EFA and CFA results showed that the questionnaire on teacher motivation formed three distinct factors including (1) English curriculum-related factors, (2) teacher-related factors, and (3) teaching method-related factors and on teachers' hindrances with three factors, consisting (4) English curriculum-related factors, (5) teacher-related factors, and (6) institution-related factors.

5.1 Teachers' impetus for CBETC enactment

Factors related to the English program reflect teachers' beliefs in the core values of CBETC, including the development of practical language skills, critical thinking, and communication skills for students. Teachers perceive CBETC as consistent with modern educational goals and helping students integrate into the real world (Voogt & Roblin, 2012; Richards & Rodgers, 2014). This indicates that teachers know the shift from teaching knowledge to teaching competence – an important condition for ensuring support and effective program implementation (Priestley et al., 2015).

Next, teacher-related factors reflect their intrinsic motivation, including their commitment to the profession, desire for innovation, and willingness to experiment with new forms of teaching. This factor reflects the active role of teachers in the teaching and learning system (Engeström, 2001). This result is consistent with the study of Griffith & Lim (2014), emphasizing that teachers are not only implementers of the curriculum but also creators of the curriculum through reflective practice.

In addition, teaching methods show that teachers consider methodological innovation as the primary means to implement CBETC. Manifestations such as personalizing learning, integrating diverse methods, and organizing activities according to competencies show the deep integration of CBETC philosophy into pedagogical practice. In contrast to previous studies that focused on teaching difficulties (Wong, 2008), this finding emphasizes the role of intrinsic motivation as a condition to promote fundamental transformation in the classroom.

5.2. Teachers' hindrances to enact CBETC

In addition to the positive drivers, the study identified three main barrier groups. First, factors related to the English curriculum reflect a lack of specificity in the in-depth guidance for implementing CBETC and ambiguity in the orientation of practice. Teachers have difficulty translating the curriculum content into feasible lesson plans. This result is consistent with Carlgren's (2020) observation of the mismatch between the intended and implemented curricula. It is similar to the survey results of Nguyen et al. (2023) in the Vietnamese context.

Next, factors related to teachers reflect limitations in the knowledge, skills, and pedagogical beliefs of the teachers in the classroom. Lack of understanding of CBETC, feelings of incompetence in designing competency-based activities, and reluctance to innovate methods indicate the important mediating role of

teachers in implementing the program (Spillane et al., 2002). Similarly, Altinyelken's (2010) study also found that misperceptions or lack of confidence in the program were among the main reasons hindering educational innovation.

Meanwhile, institutional factors were a group of systemic barriers, including a lack of teaching resources, support from school leaders, and difficulties in transforming traditional to competency-based teaching. These barriers suggest that CBETC cannot be effectively implemented without an organizational environment that supports innovation. This is similar to Wong's (2008) study, in which teachers often felt alone when implementing reform in an unprepared system.

The simultaneous facilitators and barriers in the EFA and CFA results suggest that CBETC implementation is a complex process intertwined between intrinsic motivation and external conditions. The validation of these six factors confirms the theoretical model proposed in the study – a systemic model linking people, tools, and context (Engeström, 2001; Carlgren, 2020).

In practice, the validated questionnaire can assess teachers' readiness, awareness, and difficulties in different contexts of CBETC implementation. The results also suggest that educational reform policies must be synchronized at all three levels: raising curriculum clarity, developing teacher capacity, and improving institutional readiness.

5.3 Application of EFA and CFA in developing and testing questions about factors affecting the implementation of CBETC program

In educational research, especially studies of abstract elements such as motivation and obstacles, the development and testing of measurement tools play a key role in ensuring the reliability and value of data. In the context of research on CBETC, two methods of analyzing the discovery factor (EFA) and an analysis of the affirmation factor (CFA) are commonly used to develop and establish a measurement model for the questionnaire that surveyed the factors affecting the implementation of this program (Developsis, 2016; Hair et al., 2019).

EFA allows for exploring latent structures among observed variables without imposing a theoretical model in advance, thereby identifying factor groups that fit the empirical data. This is an important initial step to ensure survey items' statistical and theoretical validity (Fabrigar & Wegener, 2012). After establishing a preliminary model, CFA is deployed to test the suitability of the hypothesized model to the data and evaluate the indicators of convergent validity, discriminant validity, and composite reliability (Brown, 2015; Kline, 2016). The combined use of EFA and CFA on two separate data sets or through a split-sample technique helps to minimize the risk of overfitting and increase the generalizability of the instrument (Worthington & Whittaker, 2006).

However, this method also has some limitations. EFA is exploratory and can be influenced by subjective decisions such as the number of factors or rotation method (Costello & Osborne, 2005). CFA requires large sample sizes and can be influenced if the theoretical model is not established beforehand. However, when applied systematically, EFA and CFA remain robust and reliable questionnaire development and validation methods in CBETC research.

6 Conclusion

Based on the theoretical foundations of Activity Theory (Engeström, 2001) and the three-tier curriculum model (Carlgren, 2020), the questionnaire was developed to reflect two main aspects of teachers' curriculum implementation behavior: impetus and hindrances. With the successful construction and validation of a questionnaire to measure factors affecting the implementation of CBETC in general schools in Vietnam using two methods, EFA and CFA, this article provides a highly reliable tool for measuring teachers' impetus and teachers' hindrances.

In the field of education, especially in the context of Vietnam's transition to a competency-based education model, this study brings many practical and academic contributions. First, the study developed a questionnaire with a clear theoretical basis, validated by modern quantitative methods (EFA and CFA), contributing to filling the measurement gap in research on implementing innovative educational programs. This tool can be used in practical studies to measure the motivation and obstacles of general education teachers.

Second, the study established a six-factor model combining individual and organizational factors, reflecting program implementation behavior's multidimensional and systematic nature. This is consistent with Engeström's (2001) recommendation that educational change cannot come from individuals alone but needs to be placed in the context of activities and relationships between people, tools, community, and rules.

Finally, the study clarifies the relationship between beliefs, capacities, and the environment of implementation in CBETC - an aspect many previous studies have mentioned sporadically. Identifying drivers and barriers helps inform systemic policy recommendations, such as redesigning CBETC instructional materials, investing in ongoing teacher professional development, and building a culture of support for school reform.

References

- Altinyelken, H. K. (2010). Curriculum change in Uganda: Teacher perspectives on the new thematic curriculum. *International Journal of Educational Development, 30*(2), 151–161. <https://doi.org/10.1016/j.ijedudev.2009.03.004>
- Artino, A. R., Jr., La Rochelle, J. S., Dezee, K. J., & Gehlbach, H. (2014). Developing questionnaires for educational research: AMEE Guide No. 87. *Medical Teacher, 36*(6), 463–474. <https://doi.org/10.3109/0142159X.2014.889814>
- Auerbach, E. R. (1986). Competency-based ESL: One step forward or two steps back? *TESOL Quarterly, 20*(3), 411–429. <https://doi.org/10.2307/3586501>
- Alamer, A. (2025). *Structural equation modeling (SEM) in L2 writing research: Simple tutorial and useful recommendations. Research Methods in Applied Linguistics, 4*(2), Article 100202. <https://doi.org/10.1016/j.rmal.2025.100202>
- Barab, S. A., Barnett, M., & Squire, K. (2002). Developing an empirical account of a community of practice: Characterizing the essential tensions. *The Journal of the Learning Sciences, 11*(4), 489–542.
- Beijaard, D., Meijer, P. C., & Verloop, N. (2004). Reconsidering research on teachers' professional identity. *Teaching and Teacher Education, 20*(2), 107–128. <https://doi.org/10.1016/j.tate.2003.07.001>
- Borg, S. (2006). *Teacher cognition and language education: Research and practice*. Continuum.
- Borko, H. (2004). Professional development and teacher learning: Mapping the terrain. *Educational Researcher, 33*(8), 3–15. <https://doi.org/10.3102/0013189X033008003>
- Boateng, G. O., Neilands, T. B., Frongillo, E. A., Melgar-Quinonez, H., & Young, S. L. (2018). Best practices for developing and validating scales for health, social, and behavioral research: A primer. *Frontiers in Public Health, 6*(1), 149.
- Brown, T. A. (2015). *Confirmatory factor analysis for applied research* (2nd ed.). Guilford Publications.
- Byrne, B. M. (2016). *Structural equation modeling with AMOS: Basic concepts, applications, and programming* (3rd ed.). Routledge.
- Byrne, B. M. (2010). *Structural Equation Modeling With AMOS: Basic Concepts, Applications, and Programming* (2nd ed.). Routledge. <https://doi.org/10.4324/9780203805534>

- Carlgren, D. (2020). Competency-based curriculum transition: A conceptual framework. *Competency-Based Education*, 6(2), 1-8. <https://onlinelibrary.wiley.com/doi/full/10.1002/cbe2.1229>
- Costello, A. B., & Osborne, J. W. (2005). Best practices in exploratory factor analysis: Four recommendations for getting the most from your analysis. *Practical Assessment, Research & Evaluation*, 10(7), 1-9.
- Creswell, J. W., & Creswell, J. D. (2018). *Research design: Qualitative, quantitative, and mixed methods approaches* (5th ed.). SAGE Publications.
- Deci, E. L., & Ryan, R. M. (2000). The “what” and “why” of goal pursuits: Human needs and the self-determination of behavior. *Psychological Inquiry*, 11(4), 227-268. https://doi.org/10.1207/S15327965PLI1104_01
- DeVellis, R. F. (2016). *Scale development: Theory and applications* (4th ed.). Sage.
- Engeström, Y. (2001). Expansive learning at work: Toward an activity theoretical reconceptualization. *Journal of Education and Work*, 14(1), 133-156.
- Etikan, I., Musa, S. A., & Alkassim, R. S. (2016). Comparison of convenience sampling and purposive sampling. *American Journal of Theoretical and Applied Statistics*, 5(1), 1-4. <https://doi.org/10.11648/j.ajtas.20160501.11>
- Evans, J. R., & Mathur, A. (2018). *The value of online surveys*. *Internet Research*, 28(4), 854-887. https://www.researchgate.net/publication/220146842_The_Value_of_Online_Surveys
- Fabrigar, L. R., & Wegener, D. T. (2012). *Exploratory factor analysis*. Oxford University Press. <https://doi.org/10.1093/acprof:osobl/9780199734177.001.0001>
- Fabrigar, L. R., Wegener, D. T., MacCallum, R. C., & Strahan, E. J. (1999). Evaluating the use of exploratory factor analysis in psychological research. *Psychological Methods*, 4(3), 272-299. <https://doi.org/10.1037/1082-989X.4.3.272>
- Field, A. (2018). *Discovering statistics using IBM SPSS Statistics* (5th ed.). Sage Publications.
- Fullan, M. (2007). *The new meaning of educational change* (4th ed.). Teachers College Press.
- George, D., & Mallery, P. (2003). *SPSS for Windows step by step: A simple guide and reference* (4th ed.). Allyn & Bacon.
- Griffith, W. I., & Lim, H.-Y. (2014). Introduction to competency-based language teaching. *MEXTESOL Journal*, 38(2), 1-9. <https://www.mextesol.net/journal/public/files/e1960d15064530ba085a29622583de18.pdf>
- Guskey, T. R. (2002). Professional development and teacher change. *Teachers and Teaching: Theory and Practice*, 8(3), 381-391. <https://doi.org/10.1080/135406002100000512>
- Hair, J. F., Black, W. C., Babin, B. J., & Anderson, R. E. (2019). *Multivariate data analysis* (8th ed.). Cengage Learning.
- Hord, S. M. (1997). *Professional learning communities: Communities of continuous inquiry and improvement*. Southwest Educational Development Laboratory (SEDL). <https://files.eric.ed.gov/fulltext/ED410659.pdf>
- Hu, L. T., & Bentler, P. M. (1999). Cutoff criteria for fit indexes in covariance structure analysis: Conventional criteria versus new alternatives. *Structural Equation Modeling: A Multidisciplinary Journal*, 6(1), 1-55. <https://doi.org/10.1080/10705519909540118>
- Kelchtermans, G. (2009). Who I am in how I teach is the message: Self-understanding, vulnerability and reflection. *Teachers and Teaching: Theory and Practice*, 15(2), 257-272. <https://doi.org/10.1080/13540600902875332>
- Kline, R. B. (2016). *Principles and practice of structural equation modeling* (4th ed.). Guilford Press.

- Kaiser, H. F. (1974). An index of factorial simplicity. *Psychometrika*, 39(1), 31–36. <https://doi.org/10.1007/BF02291575>
- Leat, D., Livingston, K., & Priestley, M. (2013). Curriculum for excellence through critical dialogue. In M. Priestley & G. Biesta (Eds.), *Reinventing the curriculum: New trends in curriculum policy and practice* (pp. 204–222). Bloomsbury Academic.
- Meade, A. W., & Craig, S. B. (2012). Identifying careless responses in survey data. *Psychological Methods*, 17(3), 437–455. <https://doi.org/10.1037/a0028085>
- Mulder, M. (2017). *Competence-based vocational and professional education: Bridging the worlds of work and education*. Springer.
- MOET (Ministry of Education and Training). (2018). *General education curriculum – English language curriculum*. Hanoi, Vietnam
- Nguyen, T. A., Le, T. T., Vang, M. D., Phuong, Y. H., Huynh, T. T. A., Nguyen, T. H., & Pham, T. T. (2023). Vietnamese EFL high school teachers' perceptions of difficulties when implementing competency-based English teaching curriculum and their proposed solutions. *Forum for Linguistic Studies*, 5(2), 1863. <https://doi.org/10.59400/fls.v5i2.1863>
- Nieveen, N., & Kuiper, W. (2012). Balancing curriculum freedom and regulation in local curriculum development. *European Educational Research Journal*, 11(3), 357–368. <https://doi.org/10.2304/eej.2012.11.3.357>
- Nunnally, J. C., & Bernstein, I. H. (1994). *Psychometric theory* (3rd ed.). McGraw-Hill.
- Orafi, S. M. S., & Borg, S. (2009). Intentions and realities in implementing communicative curriculum reform. *System*, 37(2), 243–253. <https://doi.org/10.1016/j.system.2008.11.004>
- Opfer, V. D., & Pedder, D. (2011). Conceptualizing teacher professional learning. *Review of Educational Research*, 81(3), 376–407. <https://doi.org/10.3102/0034654311413609>
- OECD. (2018). *The future of education and skills: Education 2030 – The OECD learning compass 2030*. OECD Publishing. <https://www.oecd.org/education/2030-project/>
- Pallant, J. (2020). *SPSS survival manual* (7th ed.). Open University Press.
- Priestley, M., Biesta, G., & Robinson, S. (2015). *Teacher agency: An ecological approach*. Bloomsbury Publishing.
- Remillard, J. T. (2005). Examining key concepts in research on teachers' use of mathematics curricula. *Review of Educational Research*, 75(2), 211–246. <https://doi.org/10.3102/00346543075002211>
- Richardson, V. (1996). The role of attitudes and beliefs in learning to teach. In J. Sikula (Ed.), *Handbook of research on teacher education* (2nd ed., pp. 102–119). Macmillan.
- Richards, J. C., & Rodgers, T. S. (2014). *Approaches and methods in language teaching* (3rd ed.). Cambridge University Press.
- Spady, W. G. (1994). *Outcome-based education: Critical issues and answers*. American Association of School Administrators.
- Spillane, J. P., Reiser, B. J., & Reimer, T. (2002). Policy implementation and cognition: Reframing and refocusing implementation research. *Review of Educational Research*, 72(3), 387–431. <https://doi.org/10.3102/00346543072003387>
- Taherdoost, H. (2016). Validity and reliability of the research instrument; how to test the validation of a questionnaire/survey in a research. *International Journal of Academic Research in Management*, 5(3), 28–36. <https://doi.org/10.2139/ssrn.3205040>
- Tabachnick, B. G., & Fidell, L. S. (2013). *Using Multivariate Statistics* (6th ed.). Pearson Education.
- Vähäsantanen, K. (2015). Professional agency in the stream of change: Understanding educational change and teachers' professional identities. *Teaching and Teacher Education*, 47, 1–12. <https://doi.org/10.1016/j.tate.2014.11.006>

- Vescio, V., Ross, D., & Adams, A. (2008). A review of research on the impact of professional learning communities on teaching practice and student learning. *Teaching and Teacher Education, 24*(1), 80–91. <https://www.psychosphere.com/A%20review%20on%20research%20on%20the%20impact%20of%20PLCs%20on%20teaching%20practice%20&%20student%20learning%20by%20Vescio,%20Ross%20&%20Adams.pdf>
- Voogt, J., & Roblin, N. P. (2012). A comparative analysis of international frameworks for 21st-century competencies: Implications for national curriculum policies. *Journal of Curriculum Studies, 44*(3), 299–321. <https://doi.org/10.1080/00220272.2012.668938>
- Wiggins, G., & McTighe, J. (2005). *Understanding by design* (Expanded 2nd ed.). ASCD.
- Worthington, R. L., & Whittaker, T. A. (2006). Scale development research: A content analysis and recommendations for best practices. *The Counseling Psychologist, 34*(6), 806–837. <https://doi.org/10.1177/0011000006288127>
- Wong, R. M. H. (2008). *Competency-based English teaching and learning: Investigating pre service teachers of Chinese's learning experience*. *Porta Linguarum, 9*(1), 179-198. http://www.ugr.es/~portalin/articulos/PL_numero9/13%20Ruth%20Ming.pdf

Mr. Chau Vinh THANH is an English lecturer pursuing a PhD in TESOL at Ho Chi Minh City Open University. His main research interests are English learning and teaching, curriculum design, teaching methods, autonomous learning and teaching. ORCID: <https://orcid.org/0009-0001-1508-42811>

Associate Professor **Dr. Tran Quoc Thao** is currently working at the Faculty of Foreign Languages, Ho Chi Minh City Open University. He has been teaching English for 20 years, and he is experienced in teaching English to both local and international students. His research areas are discourse analysis, English language skills, teacher professional development and instructional design model.